

**Volume**

**1.1**

# **OPERATIONAL MANUAL**

---

MODEL: **BRM-60** MAGNETIC DRILLING MACHINE

---



**by BLUEROCK® Tools**

**UNPACKING THE ITEM**

Caution: This machine is packed together with items that may be sharp, oily and overly heavy objects. Remove the machine from the packaging in a safe manner. Check to ensure all accessories are included with the item while unpacking. If any parts are found to be missing, contact the retailer as soon as possible. Do not throw away the packaging until the item is out of the guarantee period. Dispose of the packaging in an environmentally responsible manner. Recycle if possible. Keep all plastic bags away from children due to risk of suffocation.



WEEE - Waste Electrical & Electronic Equipment. Note this machine should be disposed of as electrical & electronic waste.

## Table of Contents

<b>SAFETY</b>	<b>1</b>
<i>PRE-OPERATIONAL SAFETY CHECKS</i>	1
<i>OPERATIONAL SAFETY CHECKS</i>	1
<b>SPECIFICATIONS</b>	<b>4</b>
<b>INCLUDED ACCESSORIES</b>	<b>4</b>
<b>ADDITIONAL AVAILABLE ACCESSORIES</b>	<b>5</b>
<b>ADDITIONAL ACCESSORIES FOR THIS MACHINE CAN BE FOUND IN <b>BLUEROCK®</b> TOOLS ONLINE SHOP AT <a href="http://WWW.BLUEROCKTOOLS.COM">WWW.BLUEROCKTOOLS.COM</a> OR FROM YOUR LOCAL RETAILER.</b>	<b>5</b>
<b>OPERATIONS</b>	<b>6</b>
<i>PURPOSE</i>	6
<i>OPERATIONAL PRINCIPLES</i>	6
<i>MACHINE COMPONENTS</i>	6
<i>TRANSPORTING THE MACHINE</i>	8
<i>RUNNING THE MACHINE</i>	8
<i>INSTALLING ANNULAR CUTTERS</i>	10
<b>TROUBLESHOOTING</b>	<b>12</b>
<b>GENERAL MAINTENANCE</b>	<b>13</b>
<b>OCCASIONAL MAINTENANCE</b>	<b>13</b>
<b>PARTS LIST</b>	<b>14</b>
<b>BREAKDOWN VIEW - MOTOR/GEARBOX CLOSE-UP</b>	<b>15</b>
<b>BREAKDOWN VIEW - FRAME/ELECTRICAL CLOSE-UP</b>	<b>16</b>

---

## Safety

**DO NOT USE THIS MACHINE UNLESS YOU HAVE READ THE OPERATING INSTRUCTIONS!**



Safety glasses must be worn at all times in work areas.



Long and loose hair must be contained.



Appropriate footwear must be worn.



Close fitting/protective clothing must be worn.



Safety gloves should be worn at all times and jewelry must not be worn.



Hearing protection should be worn when using this machine.



Hard-hat must be worn while using machine.



Dust mask must be worn while using this machine.



Read operational manual prior to use.

### PRE-OPERATIONAL SAFETY CHECKS

- Examine the power cord and plug for damage. This tool is supplied with a ground plug and must always be used with the proper grounded circuit.
- Examine the body of the machine and inspect for damage or defects.

### OPERATIONAL SAFETY CHECKS

- ONLY to be operated by qualified personal who have read instructions.
  - NOTE: Failure to read and follow instructions could result in electrical shock, fire, property damage and/or serious injury!
- DO ensure all non-essential people are clear of the immediate work area.
- DO keep body parts, clothing & power cords clear of turning/cutting pieces. Stay alert and use common sense when using this tool.

**BRM-60 MAG DRILL**

➤ <b>DO allow machine to reach operating speed before starting a hole.</b>
➤ <b>DO unplug machine while changing or adjusting cutting bits so as not to accidentally turn machine on.</b>
➤ <b>DO remove adjusting keys or hex wrenches prior to turning the machine on.</b>
➤ <b>DO use cutting paste (instead of cutting oil) when using this drill in an inverted position to prevent oils from entering the electrical system and for ease of cutting.</b>
➤ <b>DO tie a loop in any extension cord connections to prevent cords coming apart and a loss of power.</b>
➤ <b>DO guard against electric shock by preventing body contact with grounded surfaces such as pipes, radiators, ranges, refrigerators, etc.</b>
➤ <b>DO be mindful that power tools can expose an operator to vibrations transmitted through contact with the machine. Prolonged exposure can lead to medical issues which should be discussed with a medical professional.</b>
➤ <b>DO tie in a drip loop in the power cord to prevent cutting fluid from running into the power receptacle.</b>
➤ <b>DO use a dust extraction system for cutting materials that create dust such as cast iron. The operator should also wear a protective respiratory device.</b>
➤ <b>DO NOT make adjustments to machine while the machine is running.</b>
➤ <b>DO NOT switch off the machine when it is under load, except in an emergency.</b>
➤ <b>DO NOT remove or modify grounding plug. Only to be used on a properly grounded circuit.</b>
➤ <b>DO NOT leave the machine running when not in use.</b>
➤ <b>DO NOT hold the work piece by hand or using body. Always mechanically clamp or secure work piece.</b>
➤ <b>DO NOT allow coolant oil to enter the machine's ventilation system.</b>
➤ <b>DO NOT operate machine outside of machine specifications.</b>
➤ <b>DO NOT touch moving parts while the machine is running as death or dismemberment could occur.</b>
➤ <b>DO NOT remove machine metal panels while machine is connected to a power source. Only to be removed for service by qualified personal and put back on the machine after service is complete.</b>
➤ <b>DO NOT allow children or untrained personal to operate machine.</b>
➤ <b>DO NOT use this machine in the rain or a wet environment. If using outdoors, make sure the adhering surface is clean and dry.</b>
➤ <b>DO NOT operate in the presence of explosive materials as power tools create sparks which may ignite dust or fumes.</b>
➤ <b>DO NOT drill into an area that may contain a live electrical wire/circuit.</b>

➤ **DO NOT** operate this machine on the same work surface where welding is being performed. This could result in severe damage to the machine or personal injury to the user.

➤ **DO NOT** use this machine without the safety chain or safety strap.

➤ **DO NOT** operate this machine on a lower voltage as it may result in the electromagnet being at a reduced power level and the machine could become unstable while cutting. This could also limit the motor life.

○ **NOTE:** Use of long small gauge power extension cords can result in decreased voltage. As local voltages can vary, it may be a good idea to test the voltage at the end of the extension cord to ensure proper voltage requirements are met. You might also consult an electrician to make sure the length of cord matches up with the proper wire gauge for this size motor. Make sure to use outdoor cords when operating outdoors.

BLUEROCK® TOOLS

## Specifications

<b>ELECTRICAL DATA</b>	
Voltage	120V, 60Hz
Current	15.4 Amps
Motor Size	1850W
Power Connection	US Standard 3 Prong Type B Plug

<b>MECHANICAL DATA</b>	
Motor Reverse	Yes
Cutter Range	Annular Cutter: 7/16" Min to 2-1/4" Max (12mm - 60mm) Standard Twist Drill Bit: Max 1-1/4" (32mm)
Cutting Depth	2" (50mm) Max Depth
Cutting Speed	260/470 RPM Two Speed Gearbox
Tool Holder	MT3 Arbor
Magnetic Adhesion	4050 Lbs (18000N)
Stroke	7.75"

<b>SHIPPING DATA</b>	
Shipping Weight	72 Lbs
Shipping Carton	28" x 10" x 21"

## Included Accessories

<b>DESCRIPTION</b>	<b>QTY</b>
Instruction Manual	1
Coolant/Oil Bottle	1
Feed Handles	3
MT Wedge Key	1
MT3-MT2 Adapter	1
MT2-MT1 Adapter	1
3/4" Weldon Shank MT3 (for annular cutters)	1
3/4" Drill Chuck with B22 MT3 Adapter (for twist bits)	1
Chuck Key	1
Safety Chain	1
Plastic Case (for protection during shipping)	1
Hex Wrench	3

**Note**

**UPON RECEIPT, CHECK CAREFULLY TO ENSURE THAT THE MACHINE IS IN GOOD CONDITION AND HAS ALL ACCESSORIES LISTED ABOVE.**

**Additional Available Accessories**

Additional accessories for this machine can be found in BLUEROCK® Tools online shop at [www.bluerocktools.com](http://www.bluerocktools.com) or from your local retailer.

<i>DESCRIPTION</i>
13 Pc 2" Depth HSS Annular Cutter Set with Centering Pin
6 Pc 2" Depth HSS Annular Cutter Set with Centering Pin
6 Pc 1" Depth HSS Annular Cutter Set with Centering Pin
MT3 Weldon Shank with Quick Disconnect
MT3 Weldon Shank without Oil Ring
MT3 Weldon Shank with Oil Ring
MT3 5/8" HD Drill Chuck



## Operations

### Note

**THOROUGHLY READ THROUGH THE ENTIRE MANUAL BEFORE OPERATING THIS MACHINE!**

#### PURPOSE

- The purpose of the BRM-60 is to drill through steel using annular cutters or standard twist drill bits.
- These drills are designed to magnetically adhere to a ferrous surface using their electromagnetic base. Generally these drills are designed and used to drill through mild steel. This magnetic base will not work without a power connection.
  - NOTE: The entire magnetic base must cover the work area to have full magnetic adhesion. Using only a portion of the magnet is dangerous! Make sure the base fits completely on the surface.
- These machines can be used vertically, horizontally or overhead (inverted) provided strong enough magnetic adhesion and an acceptable work environment. NOTE: For safety, the safety chain should always be used in case of an accidental power failure or other loss of magnetic adhesion.

#### OPERATIONAL PRINCIPLES

- The main drilling shaft rotates in a left hand or right hand direction. The main drilling motor connects to the MT3 tool holder. Either the MT3 Weldon shank or drill chuck adapters are secured in the MT3 tool holder. A cutting bit is inserted in the adapter which allows for contact with a surface and slowly bore a hole. Using the feed handles on the side of the drill, the user can raise or lower the drilling motor.

#### MACHINE COMPONENTS

- The main components of the BRM-60 are the tool holder, gearbox, motor, frame and magnetic base. The tool holder is driven by the transfer case and the motor.
  - These components must not be removed except by a qualified technician. Power must be disconnected prior to any service.

- This machine has one primary adjusting point for the travel between the magnetic base frame and the drill rail. The main way to increase or decrease the users ability to move the drill by hand is with this system. These are the black hex bolts on the side of the machine that have a locking nut around them. These are generally used to tighten up the travel as the brass slides wear over time. Be mindful to evenly adjust these so that the travel is even and smooth. The ideal travel generally keeps the drill in place when the user is not using the drill (this is usually on the tighter side) although individual users needs may vary.
- The gear adjusting point on this machine is on the side of the drill gearbox. To adjust the gear from low to high (or high to low), depress the black gear shifter and slide to the opposite side.
  - NOTE: You may need to turn the drill spindle to get the gears to properly engage while sliding the gear lock. This can be done by hand (with the drill unplugged).
- The machine has a reverse switch located on the main control panel. This switch has an “L” and “R” signifying left and right hand tool holder rotational direction.
  - NOTE: This function will only work with the drill in the off position. To reverse the direction, shut the machine off, wait for the spindle to stop spinning, toggle the switch the opposite direction and engage the motor again. The machine should switch rotational direction using this method.

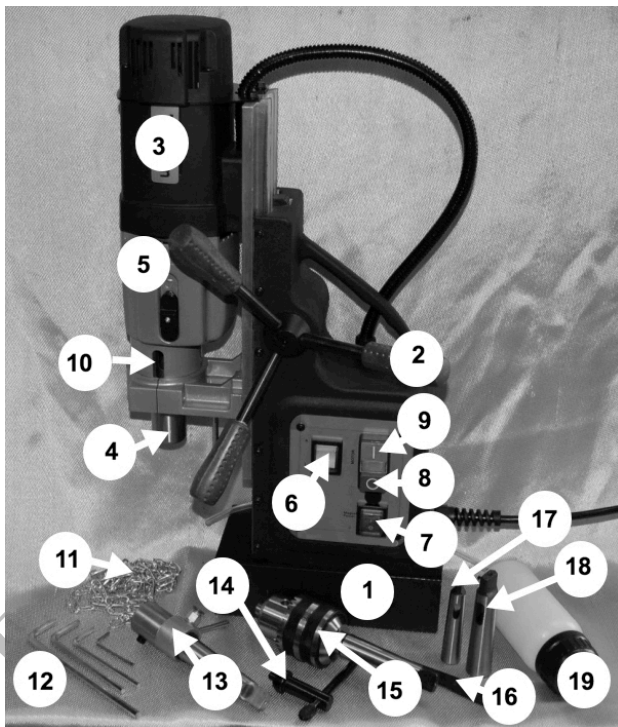

1) Magnetic Base
2) Feed Handle
3) Drill Motor
4) Tool Holder
5) Gearbox with Black Gear Shifter
6) Forward / Reverse Switch
7) Magnetic Base On/Off
8) Motor Off Switch
9) Motor On Switch
10) Tool Holder Wedge Slot
11) Safety Chain
12) Hex Keys
13) 3/4" MT3 Weldon Shank
14) Chuck Key
15) 7/8" Chuck with MT3 Adapter
16) Wedge Key
17) MT2-MT1 Adapter
18) MT3-MT2 Adapter
19) Oil Bottle

**TRANSPORTING THE MACHINE**

- When transporting the machine, always use the carrying handle.
- Ensure the drilling head is at the lowest position.
- DO NOT transport the machine with cutters or bits in the tool holder or adapters.
- If the coolant bottle is connected, ensure the valve is in the “off” position or the coolant has been drained.
- If transporting inside a vehicle, it is recommended to transport it on its side so as to avoid the item falling over.
- If possible, transport in a case.
- DO NOT carry the machine by the cord.
- DO NOT allow the cord or plug to drag along the floor when transporting.

**RUNNING THE MACHINE**

- Do all pre-operational and operational safety checks from Chapter 1.
- Consider your security and stability as well as the orientation of the machine in the work area.
  - Consider the work surface material, condition, strength, density and rigidity. These factors directly affect the tools magnetic adhesion. Magnetic adhesion diminishes with thinner material and rough surface. Full magnetic spec'd adhesion is considered on 1” material. When using on material 3/8” or less, the drill should be mechanically clamped to the work-piece.
- After placing the machine in work area, connect the safety chain.
  - The safety chain should attach to the machine (preferably through the carrying handle) as well as attached to the work area in such a manner that prevents the machine from detaching or falling from the work area in the event of magnetic deactivation or lost adhesion.
- Ensure the feed handles are securely attached to the feed spindle.
- Ensure the work surface and bottom of magnet are free of debris, oil, etc.
- Select appropriate size chuck or shank or other to use in the tool holder.
  - When inserting the MT3 chuck or Weldon shank into the MT3 tool holder, make sure to gently tap the bottom of the chuck or shank with a rubber hammer to ensure it is secure.
  - When taking out the MT3 chuck or Weldon shank, use the metal wedge key. Leading with the narrow side of the key, place into the tool holder wedge slot (seen in the above picture). If the key does not go in, slowly turn the chuck or Weldon shank until the wedge key goes though. When it reaches it maximum point gently tap the backside of the wedge key with a hammer. Make sure to hold onto the chuck or shank so it does not fall causing damage or injury.
- Select and set up oiling method or cutting pastes.

- If drilling overhead or horizontal use cutting paste liberally applied to the cutting bit.
- If using the machine horizontally with the oil bottle, connect bottle to the side of the machine using the two set screws located on the drill frame.
  - Connect the oil bottle tube into the side of the tool holder by firmly pressing in the hose.
    - To remove the hose later, press in the plastic piece around the hose towards the tool holder while simultaneously pulling the plastic hose away from the tool holder.
  - Make sure the oil bottle valve is in the off position.
    - This is generally at a 90 degree angle from the valve hose.
  - Fill the oil bottle with cutting fluid.
- Select appropriate size annular cutter or standard twist drill bit.
  - The 3/4" Weldon shank uses two Allen head bolts. The annular cutters will go in the shank and be secured on the two flat sides by the two Allen head screws. See next section below for more specifics on using annular cutters.
  - If using a standard twist drill bit you will need to tighten the bit into the chuck using the chuck key.
- Select rotational direction and speed.
- Plug the machine into power source.
  - Form a loose knot in the power cord close to the plug connection to prevent cutting fluid from running down the cord and into the power receptacle.
- Engage the magnet by pressing the magnet button on the control panel.
  - Check that the machine is firmly attached to the work area.
  - NOTE: The motor will not start unless magnet is on.
- Turn feed handle raising the cutter until the bit is above the work surface.
- Open the oil bottle valve to allow oil to come out to the work surface.
  - You may have to gently squeeze or shake the bottle to get the oil to start flowing.
- Turn the machine on.
  - Start the machine by pressing the green "on" switch. Stop the machine by pressing the red "off" switch.
- Very slowly engage the cutting bit with the material surface by lightly engaging the hand crank down towards the material.
- After about 1/16" of cutting has been achieved in the work surface, slightly more force can be applied. This will be the normal amount of force the rest of the hole.

- **NOTE: Do not force the hole. Let the machine do most of the work. Excessive physical effort should be avoided as it can cause damage to the machine or the user.**
- **If the unit jams in a hole, stop the drill immediately to prevent injury. Disconnect the drill from the power supply and loosen the cutter by turning drill spindle counterclockwise. Never attempt to free cutter by starting motor!**
- **Make sure to keep the cutting material adequately lubricated.**
- **Ease up on feed pressure as the cutter starts breaking through the backside of the material.**
- **If using annular cutters with a centering pin, the slug should eject using the spring-loaded mechanism in the drill shank. Be mindful that this slug can eject at a rapid rate, so be sure all is clear on the output side of this slug to prevent injury to persons or property.**
- **Finish drilling the hole.**
- **Turn the motor off and disconnect power once the drill is safely back up in the non-drilling position.**
- **Remove metal chips wrapped around cutter and tool holder. Use a leather glove or pliers as these metal pieces can be sharp.**
- **Disconnect safety chain and move the drill to a new drilling location.**

**INSTALLING ANNULAR CUTTERS**

- **WARNING: Annular cutters are extremely sharp and should only be handled with a thick glove so as not to cut the user during installation or removal.**
- **Check that the cutters are sharp and not damaged.**
- **Annular cutters that are dull or damaged should not be used.**
- **Insert the pilot pin into the center of the annular cutter you have chosen.**
- **NOTE: The pilot pin helps in locating the center of the hole as well as ejecting the metal slug after the cut.**
- **Make certain the machine is unplugged from power.**
- **Raise the tool holder to ensure ample room to install the cutter.**
- **If using 3/4" annular cutters, you will need to first install the 3/4" MT3 Weldon shank adapter.**
- **Insert the annular cutter into the 3/4" adapter.**
- **Align the two "flat" sides of the annular cutter with the flat sides of the adapter.**
- **CAUTION: Make certain the hex screw is seated into the flat side and not simply on the round side of the cutter shank.**

- Tighten one of the hex screws while slowly rotating the cutter forward and backwards.
  - Continue to tighten the screw until fully tightened.
- Tighten the 2<sup>nd</sup> hex screw.
- The annular cutter is ready to use.

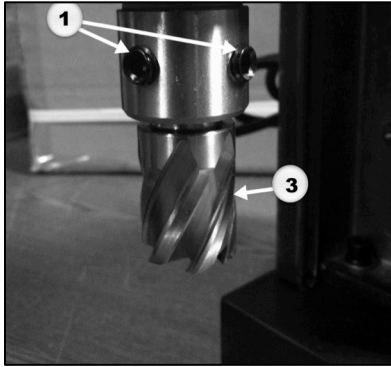

- 1) 3/4" Hex Set Screws (2 total)
- 3) Annular Cutter (not included)

BLUEROCK® TOOLS

## Troubleshooting

### Note

**SERVICING SHOULD ONLY BE DONE BY A QUALIFIED TECHNICIAN.**

**DON'T FORGET TO UNPLUG POWER TO UNIT PRIOR TO SERVICE!**

PROBLEM	SOLUTION
Motor does not turn on.	<ol style="list-style-type: none"> <li>1) Magnet not turned on. Magnet has to be engaged prior to motor working.</li> <li>2) Check external power source (extension cord, breaker, etc).</li> <li>3) Loose internal wire. Check and secure if necessary.</li> <li>4) Motor brushes defective. Replace if necessary.</li> <li>5) Check the fuse at the control panel. If it is blown, replace with same size.</li> <li>6) Check the back of the internal PC board for a short. Replace if necessary.</li> <li>7) Check the relays on the PC board to see if there are any shorts. Replace if necessary.</li> <li>8) Check to ensure the motor on/off switch is operable. Replace if necessary.</li> </ol>
Motor turns on when the magnet is turned on.	<ol style="list-style-type: none"> <li>1) PC board has a short or relays are fused in closed position. Check and replace PC board/relay if necessary.</li> </ol>
Excessive sparking when motor is running.	<ol style="list-style-type: none"> <li>1) This may indicate the presence of debris in the motor or worn out carbon brushes. Check the brushes for unusual wear and replace if necessary. Clean out the internal motor armature if necessary.</li> <li>2) Armature has a rough edge. Inspect and replace if necessary.</li> </ol>
Magnetic does not hold to work area.	<ol style="list-style-type: none"> <li>1) Work surface thickness is too small. A minimum of 3/8" (10mm) continuous ferrous steel must be used for magnetic adhesion. NOTE: It is normal to be able to push these drills off their adhesion if pushing from the top side. CAUTION: These drills do not work on sheet metal!</li> <li>2) Entire magnet base is not on the work surface.</li> <li>3) Voltage is low at the machine. Check voltage.</li> <li>4) There is debris or excess material between the work area and the magnetic base. Clean work area surface.</li> </ol>
Hole is not cutting.	<ol style="list-style-type: none"> <li>1) Cutter is dull. Sharpen or replace.</li> <li>2) Work area material is not appropriate for cutter type. High carbon type steels require special cutting bits (tungsten carbide tip, etc).</li> </ol>

## General Maintenance

➤ Inspect electrical cords and electrical connections.
➤ Keep machine clean and free of debris.
➤ Check for misalignment, binding and breakage of all moving parts. If damaged, repair tool before use.
➤ Keep cutting tools sharp and clean. Sharp cutters are less likely to bind and are easier to control.

## Occasional Maintenance

➤ Have the power tool serviced by a qualified service technician using identical replacement parts.
○ Change motor brushes:
1) Disconnect drill from power.
2) Unscrew left and right side brush holder caps.
3) Take out old brushes.
4) Replace with exact same size new brushes.
5) Screw in brush holder caps tightly.
○ Adjusting slides:
1) Periodically check, lubricate and adjust slides as necessary.
2) Use hex wrench to loosen the lock nuts and hex screws.
3) Adjust the screws evenly while moving the handle up and down so that there's no free play yet not binding anywhere through its range of travel.
4) Retighten the lock nuts.



## Parts List

1.	Flexible cable	27.	Magnetic switch	53.	Bearing 6000	79.	M5×35 screw
2.	Switch	28.	Magnetic base	54.	Gear	80.	Motor holder cap
3.	Fuse cap	29.	M5 screw nut	55.	5×5×35 key	81.	Drill holder plate
4.	Fuse	30.	M5×16 screw	56.	Gear	82.	Electro induction
5.	Fuse holder	31.	Bearing	57.	Bearing 6001	83.	Brush cap
6.	Motor starter	32.	Bearing	58.	Speeder staff	84.	Brush
7.	Cable protector	33.	Internal slide	59.	Catch spring	85.	Brush holder
8.	Cable holder	34.	Slide	60.	Gear	86.	Capacity
9.	Plate	35.	Slide	61.	Bearing 6004	87.	Connect cap
10.	M4×8 screw	36.	M5×8 screw	62.	M4×20 screw	88.	Cable fixer
11.	Handle holder	37.	Plate	63.	Speeder slide	89.	M4×12 screw
12.	Handle	38.	Rack	64.	Tube	90.	Motor holder
13.	4×10 key	39.	M6×20 screw	65.	Spring	91.	Field core
14.	Axle	40.	Hook	66.	M6×65 screw	92.	Wind catcher
15.	5×15 key	41.	Tank	67.	Gear box	93.	Bearing 6200
16.	Gear	42.	Valve	68.	Bearing 6006	94.	Motor
17.	Stop plate	43.	M6×10 screw	69.	Catch spring	95.	Bearing 6201
18.	M6×10 screw	44.	M5×12 screw	70.	6×6×14key	96.	M5×80 screw
19.	Cable protector	45.	Out slide	71.	Spindle	97.	Safety strain
20.	Cable holder	46.	M6×12 screw	72.	Catch spring	98.	6mm hex wrench
21.	Machine holder	47.	Drill holder	73.	Oil holder	99.	4mm hex wrench
22.	M5×8 screw	48.	M8×30 screw	74.	Spindle	100.	
23.	Cable fixer	49.	Gear box cap	75.	M10×12 screw	101.	
24.	M4×10 screw	50.	Bearing 6000	76.	Spring	102.	
25.	Controller	51.	Gear	77.	Spring stop	103.	
26.	M6×16 screw	52.	Bearing 6000	78.	Catch spring	104.	

### Breakdown View – Motor/Gearbox Close-Up

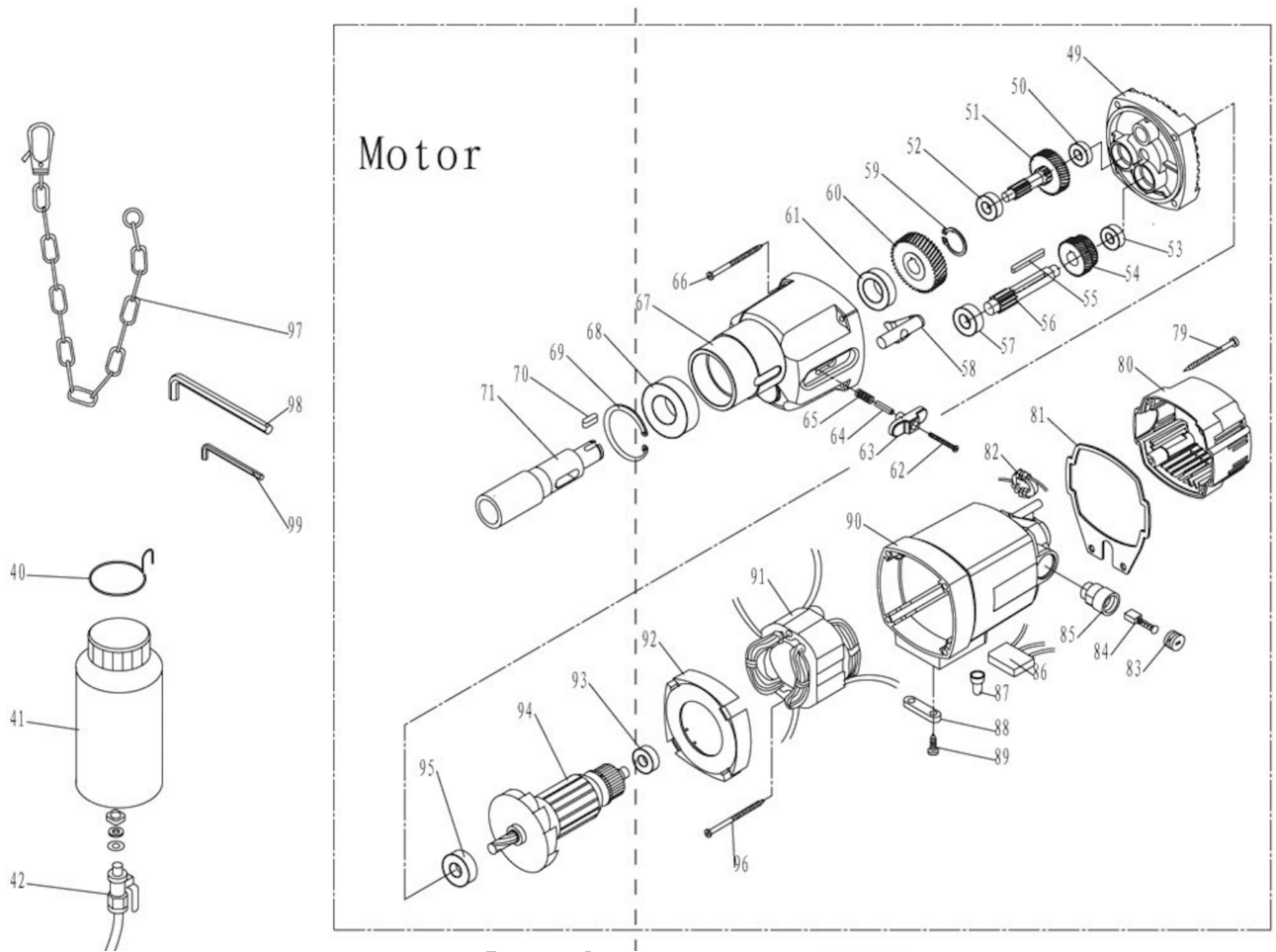

BLUERC

### Breakdown View – Frame/Electrical Close-Up

